

D38999/23 Jam Nut Mount Hermetic Receptacle MIL-DTL-38999 Series III

How To Order: **MS**

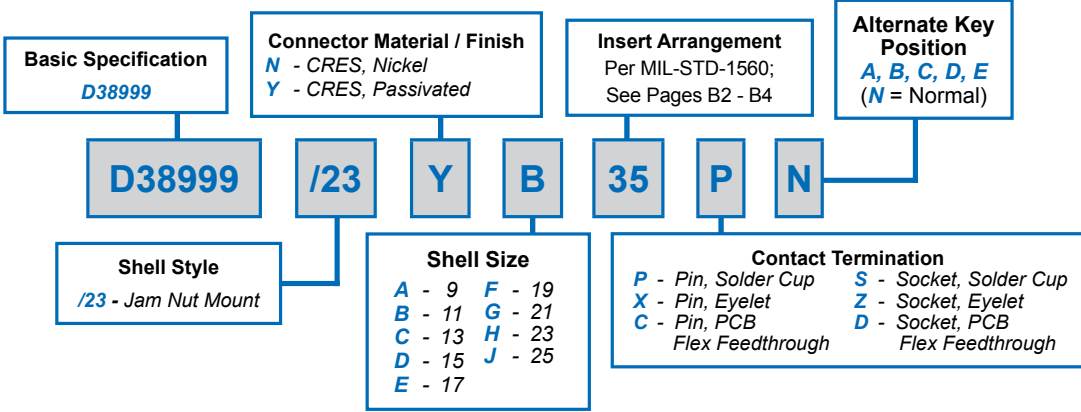

B

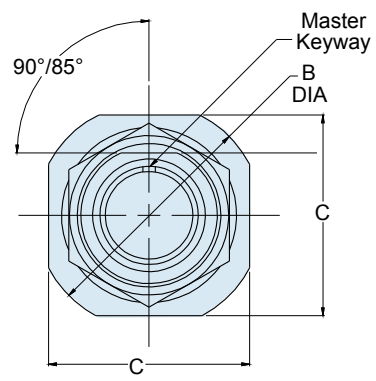
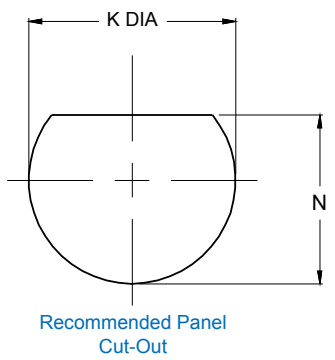
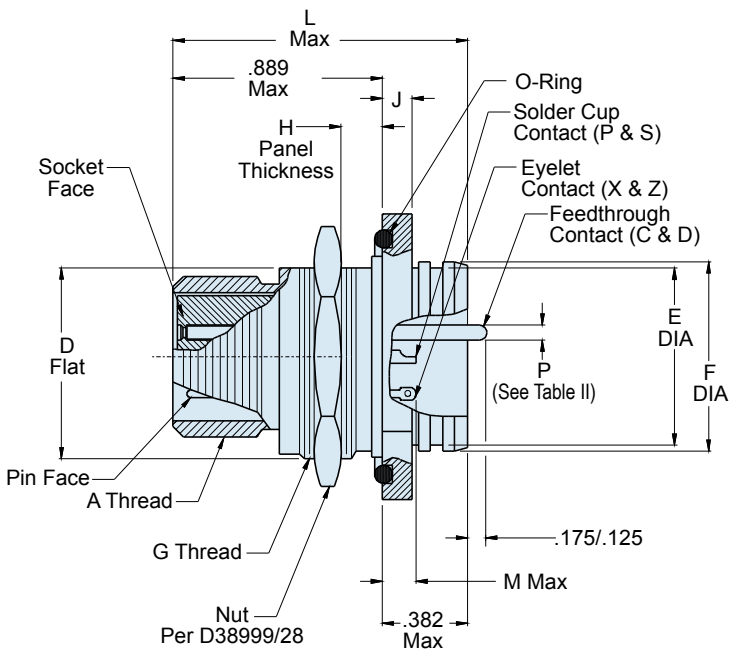

TABLE II: CONTACT SIZE

PRINTED CIRCUIT TAIL CONFIGURATIONS
CONTACT STYLE C AND D

Contact Size	ø P
22D	.011 (0.28) .015 (0.38)
20	.024 (0.61) .028 (0.71)
16	.0635 (1.61) .0615 (1.56)
12	.095 (2.41) .093 (2.36)

D38999/23 Jam Nut Mount Hermetic Receptacle MIL-DTL-38999 Series III



D38999 QPL
Hermetics

How To Order: Commercial

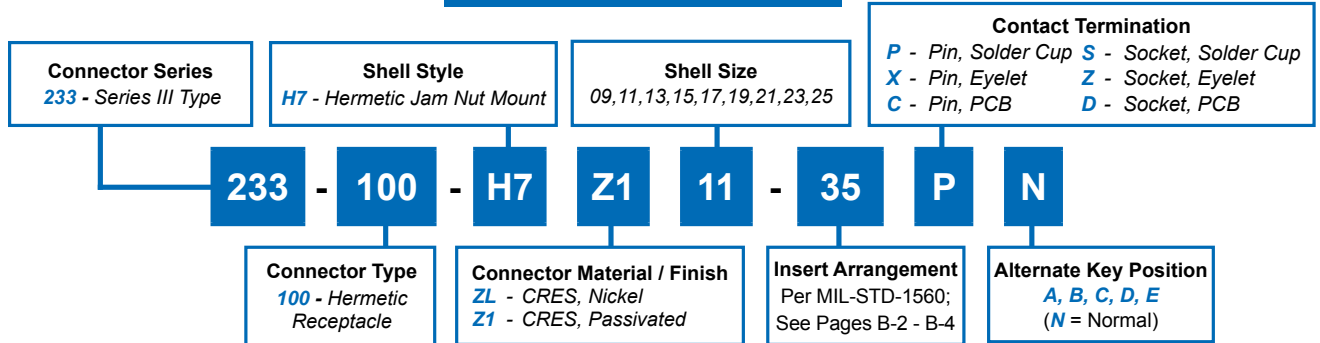

B

TABLE I: CONNECTOR DIMENSIONS

SHELL SIZE CODE	SHELL SIZE	A THREAD -0.1P-0.03L- TS	B DIA	C A/F ±.015(0.4)	D FLAT ±.005(0.1)	E DIA ±.012(0.3)	F DIA	G THREAD ISO METRIC	H ±.032(0.8)
A	9/09	0.625	1.200(30.5) 1.178(29.9)	1.063(27.0)	.650(16.5)	.603(15.3)	.653(16.6) .642(16.3)	M17 X 1.0-6g	.094(2.4)
B	11	0.750	1.385(35.2) 1.363(34.6)	1.252(31.8)	.750(19.1)	.725(18.4)	.775(19.7) .764(19.4)	M20 X 1.0-6g	.094(2.4)
C	13	0.875	1.511(38.4) 1.489(37.8)	1.374(34.9)	.937(23.8)	.851(21.6)	.905(23.0) .894(22.7)	M25 X 1.0-6g	.094(2.4)
D	15	1.000	1.637(41.6) 1.615(41.0)	1.500(38.1)	1.061(26.9)	.977(24.8)	1.031(26.2) 1.020(25.9)	M28 X 1.0-6g	.094(2.4)
E	17	1.187	1.763(44.8) 1.741(44.2)	1.626(41.3)	1.186(30.1)	1.103(28.0)	1.153(29.3) 1.142(29.0)	M32 X 1.0-6g	.094(2.4)
F	19	1.250	1.948(49.5) 1.926(48.9)	1.811(46.0)	1.311(33.3)	1.229(31.2)	1.278(32.5) 1.268(32.2)	M35 X 1.0-6g	.094(2.4)
G	21	1.375	2.074(52.7) 2.051(52.1)	1.937(49.2)	1.436(36.5)	1.351(34.3)	1.405(35.7) 1.394(35.4)	M38 X 1.0-6g	.094(2.4)
H	23	1.500	2.200(55.9) 2.177(55.3)	2.063(52.4)	1.561(39.6)	1.477(37.5)	1.531(38.9) 1.520(38.6)	M41 X 1.0-6g	.094(2.4)
J	25	1.625	2.322(59.0) 2.300(58.4)	2.189(55.6)	1.686(42.8)	1.603(40.7)	1.653(42.0) 1.642(41.7)	M44 X 1.0-6g	.094(2.4)

TABLE I: (Continued) CONNECTOR DIMENSIONS

J ±.008(0.2)	K DIA ±.005 (0.1)	L MAX	M MAX		N ±.005 (0.1)
			P&X	S&Z	
.106(2.7)	.703/.693 (17.86/17.60)	1.149(29.2)	.208(5.3)	.232(5.9)	.657/.655 (16.69/16.70)
.106(2.7)	.835/.825 (20.96/20.96)	1.149(29.2)	.208(5.3)	.232(5.9)	.771/.769 (19.58/19.53)
.106(2.7)	1.020/1.010 (25.65/25.65)	1.153(29.3)	.200(5.1)	.224(5.7)	.955/.953 (24.26/24.21)
.106(2.7)	1.145/1.135 (28.83/28.83)	1.153(29.3)	.200(5.1)	.224(5.7)	1.085/1.083 (27.56/27.51)
.106(2.7)	1.270/1.260 (32.01/32.00)	1.153(29.3)	.200(5.1)	.224(5.7)	1.210/1.208 (30.73/30.68)
.138(3.5)	1.395/1.385 (35.43/35.18)	1.185(30.1)	.200(5.1)	.224(5.7)	1.335/1.333 (33.91/33.86)
.138(3.5)	1.520/1.510 (38.60/38.35)	1.185(30.1)	.200(5.1)	.224(5.7)	1.460/1.458 (37.08/37.03)
.138(3.5)	1.645/1.635 (41.78/41.53)	1.185(30.1)	.200(5.1)	.224(5.7)	1.585/1.583 (40.26/40.21)
.138(3.5)	1.770/1.760 (44.96/44.70)	1.185(30.1)	.200(5.1)	.224(5.7)	1.710/1.708 (43.43/43.38)